

LA NOSTRA ESPERIENZA AL TUO SERVIZIO

OUR EXPERIENCE AT YOUR SERVICE
NOTRE EXPÉRIENCE À VOTRE SERVICE
NUESTRA EXPERIENCIA A SU SERVICIO

FLY 120

MADE IN ITALY

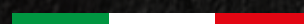

1200

agricultural machines
manufactured every year



Frontoni, fin dalla sua nascita nel **1986**, si differenzia per la costruzione di bracci decespugliatori e trinciatrici dalla grande qualità e semplicità di manutenzione. Le attrezzature agricole prodotte, grazie a una cura maniacale dei particolari, ricevono da subito l'attenzione del mercato italiano e, pochi anni dopo, grazie al numero crescente di commerciali, di quello internazionale.

Oggi l'azienda ha una capacità produttiva di oltre **1200 macchine agricole** l'anno e riesce ad abbinare la cura artigianale di sempre, a moderne tecnologie.

Questo grazie ad uno staff composto da oltre **30 persone** che si occupa dell'intero ciclo produttivo, dalla progettazione al servizio post vendita, per offrire a concessionari e utilizzatori finali velocità di consegna e un supporto tecnico competente e puntuale.

*Frontoni, since its birth in **1986**, stands out for the manufacturing of flail reach mowers and shredders with high quality and simple maintenance. The agricultural machinery manufactured, thanks to a meticulous care of details, catch immediately the attention of Italian market and, few years later, thanks to the growing number of export managers, of the International one.*

*Today, the company has a production capacity of more than **1200 agricultural machines** per year and is able to combine the artisan care of always and modern technologies.*

*All this thanks to a staff composed by over **30 employees** who deal with the production cycle, from the designing to the after-sale service, in order to offer to dealers and final users fast deliveries and competent timely technical support.*



40 years

of experience

Frontoni, depuis sa naissance en **1986**, diffère par la fabrication des débroussailleuses hydrauliques et broyeurs de grande qualité et simplicité de manutention. Les machines agricoles produites, grâce à un soin méticuleux des détails, attirent immédiatement l'attention du marché italien et, quelques années après, grâce au nombre croissant des agents commerciaux, de celui international.

Actuellement, l'entreprise a une capacité productive de plus de **1200 machines agricoles** par an et elle est capable de combiner le soin artisanal de toujours aux technologies modernes.

Tout cela grâce à une équipe composée par **30 employés** qui s'occupent du cycle de production, de la conception au service après-vente, pour offrir aux revendeurs et utilisateurs finaux livraisons rapides et support technique qualifié et ponctuel.

*Frontoni, desde sus inicios en **1986**, se caracteriza por la construcción de desbrozadoras y trituradoras de gran calidad y facilidad de mantenimiento. Los equipos agrícolas producidos, gracias a una obsesiva atención al detalle, atrajeron inmediatamente la atención del mercado italiano y, unos años más tarde, gracias al creciente número de comerciales, el internacional.*

*Hoy la empresa tiene una capacidad de producción de más de **1200 máquinas agrícolas** al año, combinando la artesanía tradicional con tecnologías modernas.*

*Gracias a una plantilla de más de **30 personas** que se ocupan de todo el ciclo productivo, diseñan el servicio postventa, ofreciendo un distribuidor y rapidez de uso final del pedido y un soporte técnico competente y puntual.*



MODEL

FLY 120



MODELLO Model	A mm	D mm	E mm	F mm	G mm	L mm
FLY 120 + CBS120-150	800	2700	4250	-	-	1200
FLY 120 + MRK3	800	2700	4450	-	-	1400
FLY 120 + MRD3-4	800	2700	4050	-	-	1050

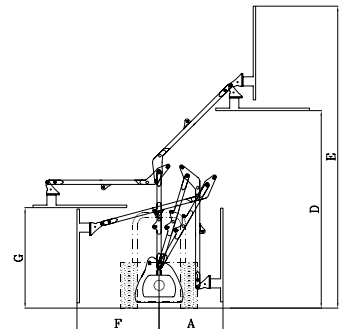

MODELLO Model	Kg.	Lt.	\varnothing MAX	Kg 500	HP 16/30	cm 900
FLY 120	220	40	cm 3	Kg 500	HP 16/30	cm 900

ATTREZZATURA INTERCAMBIABILE
INTERCHANGEABLE EQUIPMENT
ÉQUIPEMENT INTERCHANGEABLE
EQUIPO INTERCAMBIABILE



CBS 120-150



MRK 3



MRD 3-4

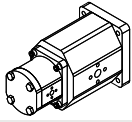

IMPIANTO IDRAULICO INDIPENDENTE
INDIPENDENT HYDRAULIC SYSTEM
 IMPLANTATION HYDRAULIQUE INDEPENDANTE
 INSTACION HIDRAULICA INDIPENDIENTE

Standard (47 l/min + 8 l/min)



BOCCOLE ANTIUSURA NEGLI SNODI
WEAR-RESISTANT BUSHES IN THE JOINTS
 DOUILLES ANTI-USURE DANS LES JOINTS
 CASQUILLOS ANTIDESGASTE EN LOS NODOS

Standard



SCAMBIATORE DI CALORE
OIL COOLER
 ECHANGEUR DE CHAULER
 INTERCAMBIADOR DE CALOR

Optional



TENDITORI DI FISSAGGIO
TRACTOR STABILIZERS
 HAUBANS DE FIXATIONS
 TENDEDORES

Optional



SUPPORTO PER FISSAGGIO TIRANTI
SPECIAL TOP LINK CONNECTION
 SUPPORT POUR FIXATION DES TIRANTS
 ATAQUE PARA FIJACIÓN TENDEDORES

Optional



KIT DI APOGGIO A TERRA ANTIRIBALTAMENTO
STABILIZED GROUND SUPPORT KIT
 KIT DE POSE-FACILE À TERRE ANTI-BASCULEMENT
 KIT DE APOYO AL SUELO STABILIZADO

Optional

TIPI DI COMANDI A DISTANZA DISPONIBILI
TYPES OF REMOTE CONTROLS AVAILABLE
 TYPES DE COMMANDES À DISTANCE DISPONIBLES
 TIPOS DE CONTROL REMOTO DISPONIBLE



Comando monoleva con cavi fless. (MM.2000)
Single lever with cables (MM.2000)
 Commandes monolevier avec cables (MM.2000)
 Sola palanca con cables (MM.2000)



Comando con cavi flessibili (MM.2000)
Cable controls (MM.2000)
 Commandes par cables teleflexibl. (MM.2000)
 Comandos a distancia teleflexibl. (MM.2000)



Comandi elettronici joystick -roller-
Electronic controls joystick -roller-
 Commandes électroniques joystick -roller-
 Comandos electrònics joystick -roller-

- Tutti i movimenti sono proporzionali ma si possono eseguire soltanto uno alla volta.
- All movements are proportional but they can be carried out one at a time.
- Touts les mouvements sont proportionnels mais ils peuvent juste être effectués un par un.
- Todos los movimientos son proporcionales pero sólo se pueden realizar solo uno a la vez.

- Tutti i movimenti sono proporzionali ma si possono eseguire soltanto uno alla volta, è presente un sistema di autolivellamento automatico comandato elettronicamente che mantiene l'attrezzatura terminale nelle condizioni 0° o 90° rispetto al terreno.
- All movements are proportional but they can be carried out one at a time, there is an automatic self-levelling electronically controlled system that keeps the interchangeable terminal tools at 0° or 90° off the ground.
- Touts les mouvements sont proportionnels mais ils peuvent être effectués un par un, il y a un système d'autonivellement contrôlé électroniquement qui tient les outils interchangeables à 0° ou 90° du sol.
- Todos los movimientos son proporcionales, pero sólo se pueden realizar solo uno a la vez. Está presente un sistema de nivelación automática controlado electrónicamente, que mantiene el equipo en las condiciones de 0° o 90° con respecto al terreno.



Joystick -roller- + autolivellamento automatico
Joystick -roller- + self levelling system
 Joystick -roller- + auto nivellement automatique
 Joystick -roller- + autonivelante automatico

- Con joystick elettronici, è indispensabile il radiatore.
- With electronic joystick, it is indispensable the radiator.
- Avec joystick électronique, le radiateur est indispensable.
- Con joystick electrónico, intercambiador de calor es indispensable.



Frontoni Maurizio s.a.s di Frontoni Maurizio & C.
Via Besenzone, 7/B - 29016 Cortemaggiore (PC) Italy
Tel. +39 (0) 523 839959
frontoni@frontoni.net - www.frontoni.net

